



KELISS™

AussieLux - S005

Smart Toilet

Auto Flush | Auto Sterilisation | Auto Foam

03 CUSTOMISABLE VERSIONS



WWW.KELISS.COM



Smart Nozzle Adjusting

Automatic Adjustment





54cm

Ergonomic design

Compared with the traditional 70cm toilet,
AussieLuxe 54cm length saves
at least 30% of space



Antibacterial

Comfortable Design to Fit Everyone



广微测
G+ Micro-Testing
广东省微生物分析检测中心
GUANGDONG MICROBIOLOGICAL ANALYSIS AND TESTING CENTER

分析检测报告
Analysis Test Report

报告编号 / Report No.: 2023FM15245R01 样品名称 / Sample Name: PP2-2636 检测方法 / Test Type: 菌落总数 / Total Viable Count

委托单位 Client Name	海纳卫浴五金制品有限公司 HAINA WARE	委托日期 Test Date	2023-08-16
样品名称 Sample Name	PP2-2636	样品数量 Sample Quantity	20
样品规格型号 Sample Specification	PP2-2636-01	检测日期 Test Date	2023-08-16
检测项目 Test Item	菌落总数		
检测依据标准 Test Standard	GB 15190.2-2008 附录 A 菌落数		

检测结果
Test Result

注: 样品名称标注的在检测报告中未检测项目。

报告编号: 2023FM15245R01

检测人: 李华
审核人: 张明
批准人: 陈伟

广微测
G+ Micro-Testing
广东省微生物分析检测中心
GUANGDONG MICROBIOLOGICAL ANALYSIS AND TESTING CENTER

分析检测报告
Analysis Test Report

报告编号 / Report No.: 2023FM15245R01

检测项目	空白对照菌落数 (cfu/g)	试验样品菌落数 (cfu/g)	抗菌率 (%)
菌落总数 (Colony-Forming Unit)	1.0e+07	<1.0e+06	≥99.9%
总菌落数 (Total Bacterial Count)	1.1e+07	<1.0e+06	≥99.9%

注: 以下空白

**检测报告显示
抗菌率≥99.9%**

报告编号: 2023FM15245R01

Antibacterial test report number: 2023FM15245R01

Easier Maintenance Integrated Design

Intelligent integrated design,
no need a separate wall-mounted water tank

Just install the load-bearing bracket



AussieLuxue Ultra

Lower Cost

Built in water tank

Lower Renovation Cost

Smaller Wall Insertion Area

Better maintenance!

Integrated external unit



Traditional Toilet

Separate Water Tank Unit

Large Scale Wall Damage

If the water tank is damaged,
maintenance is troublesome



Suspended

10cm

**High Weight
Carrying Capacity**

Built In Water Tank Booster Pump Power Flushing

Installed booster pump
ensures an effective power flush

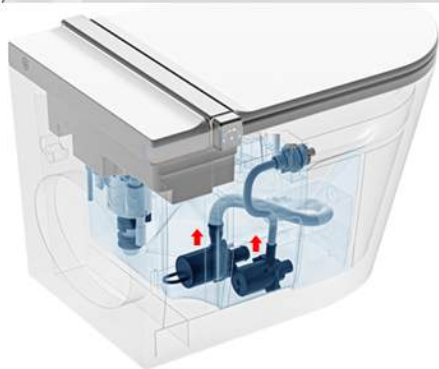

Double pump booster

Two booster pumps
for powering up

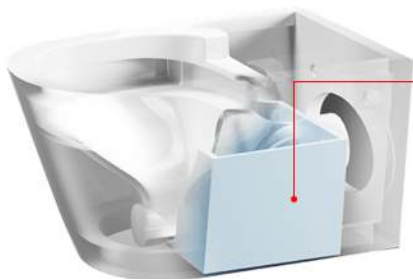

In Built Water Tank

Uninterrupted Flushing

Built In Foaming System

Easy Addition of Foaming Liquid

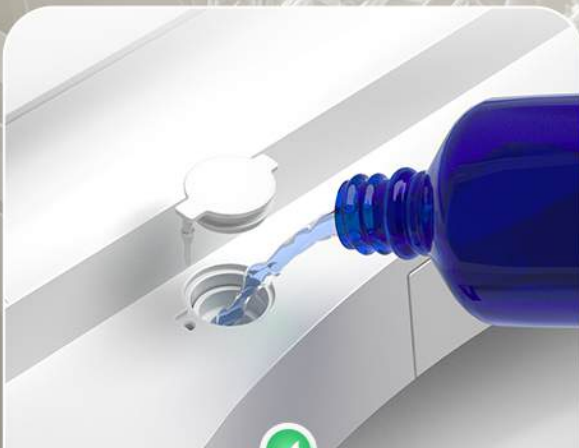

Built In System

Stylish Design

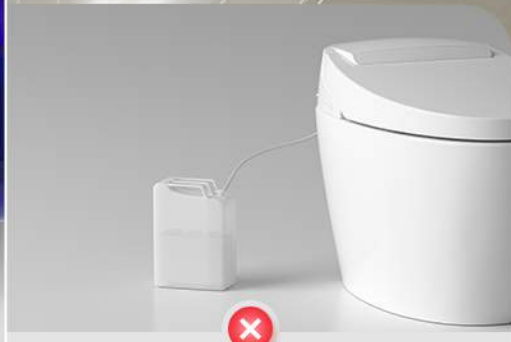

External System

Disorganised



Built In System

Foaming Liquid



Bubble Guardian

Splash-proof, odor-proof, bacteria-proof

UV Sterilization Automatic start when lid is closed



After closing the lid,
it will be automatically disinfected
for 3 minutes
through high-efficiency, high-intensity,
long-life UV radiation



Authoritative inspection report number: SZ20221658



Smart Touch-Free Technology

Lid opens when you approach
Lid closes and flush once you leave



Laser Foot Sensor

The laser foot sensor emits vertically downward and can be triggered by extending your foot. No need to lift your foot, and it is not affected by shoes.

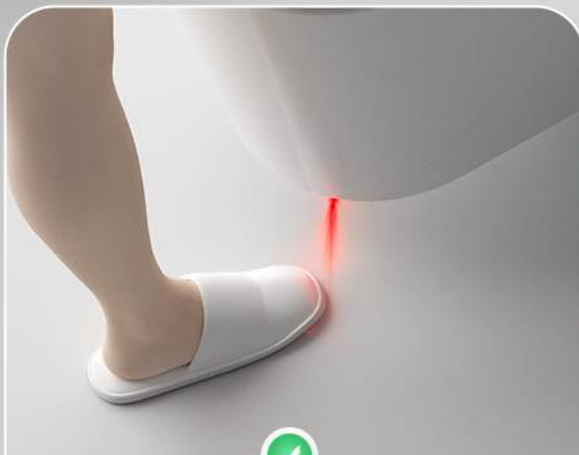
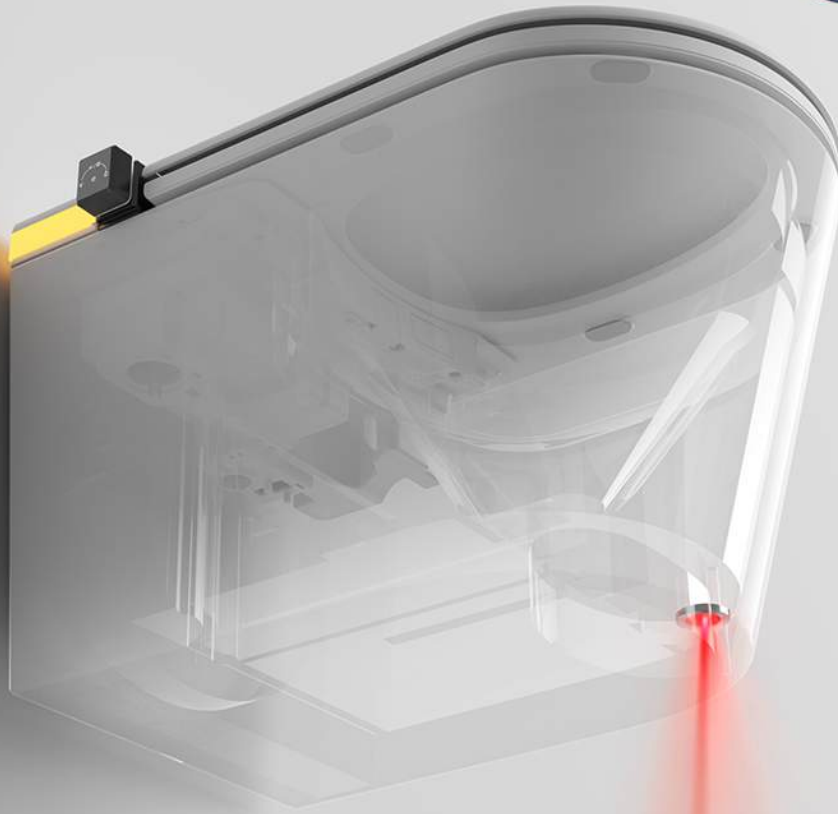

Laser Foot Sensor

Faster and
more accurate response



Manual Sensor

Less Comfortable

Easier Controls

SIDE
KNOB

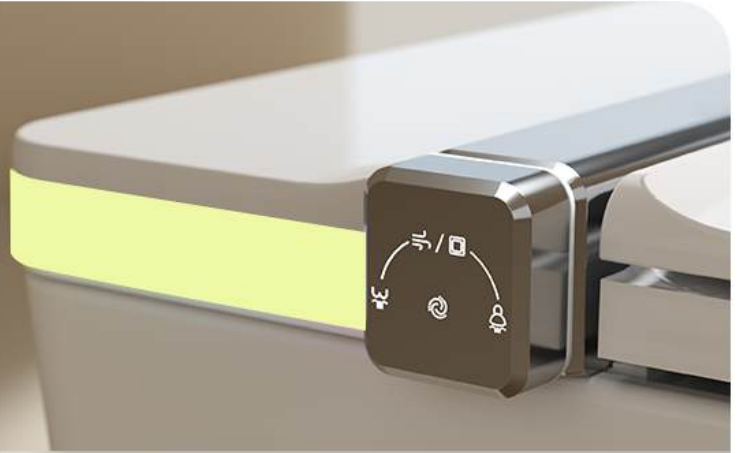

Clockwise:
Women's wash
Counterclockwise:
Rear Wash



When seated
Press once: stop
Press and hold: dry



Remote
Manual

Dual User Memory

The remote control has a built-in user memory function to record the user's toilet habits and activate the user's toilet preferences with one click.

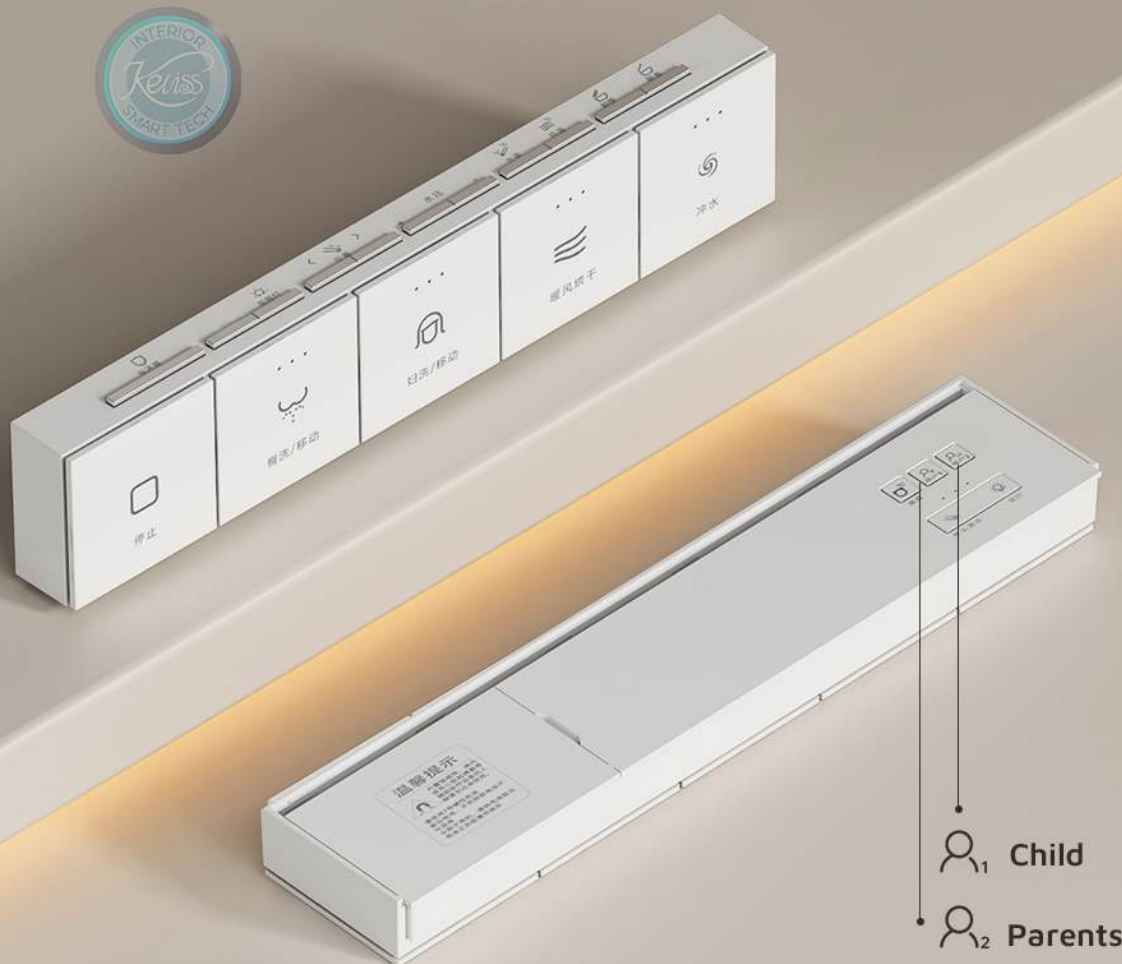

User 1: Exclusive settings for children

Seat temperature 39° | Warm air 40°
| Children's cleaning



User 2: Exclusive settings for the elderly

Seat temperature 35° | Warm air 35°
| Massage and cleaning

Colorful Rainbow Design

Color Switching Options



Four Seasons Temperature Sensor

Automatic Adjustment

As Per The Surrounding Temperature



Automatic Seat Temperature Adjustment



Automatic Water Temperature Adjustment

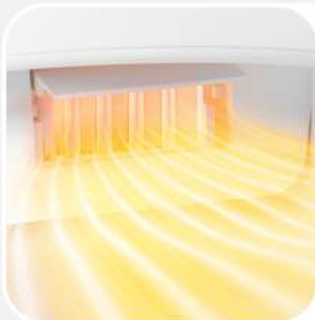
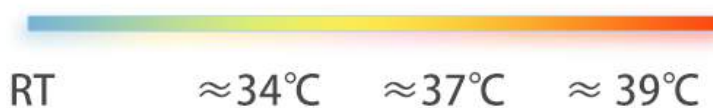

Automatic Wind Temperature Adjustment

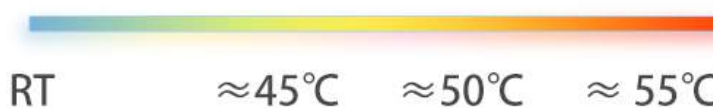

Multiple Wash Patterns

Self Cleaning Nozzle



Rear Wash

Strong Flow

01



Female Wash

Delicate and Gentle

02



Massage

Oscilating Nozzle Sprey

03

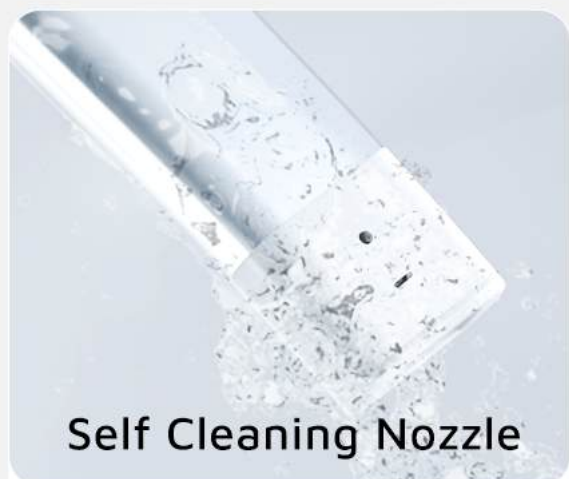

Self Cleaning Nozzle

Cleaning Befor
After Use

04

Multiple Protection Layers

Ensures Maximum Safety and Stability



Wind Overheat Protection



Water Overheat Protection



Seat Overheat Protection



Electric Insulation



Short Circuit Protection



Water and power outage protection



Exterior Water Proof



Seat ring waterproof protection

Luxury Addons



Auto Deodorisation

Starts As You Sit



LED Night Light

Mid Night Guidance



Robust LED Display

Real Time Reporting

Dimensions

Milimeters - mm

Front View

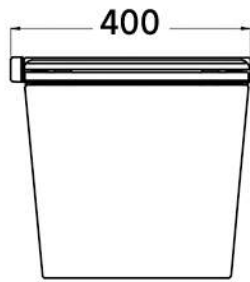

Side View

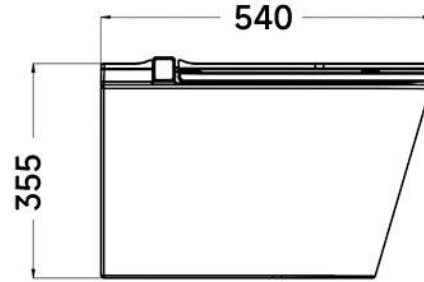

Seat Ring Inner Dia

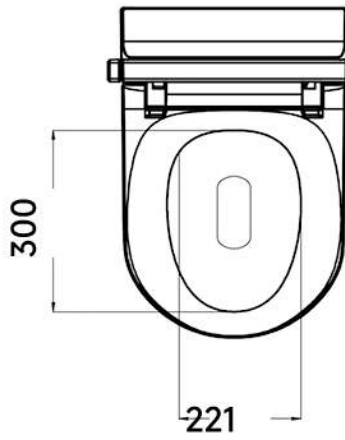

Ceramic Body Dia

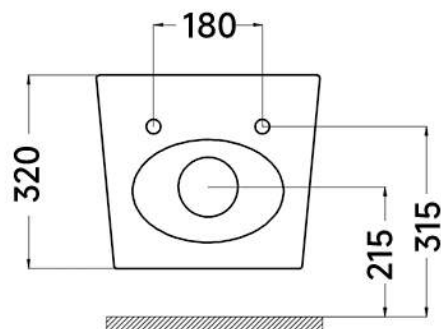
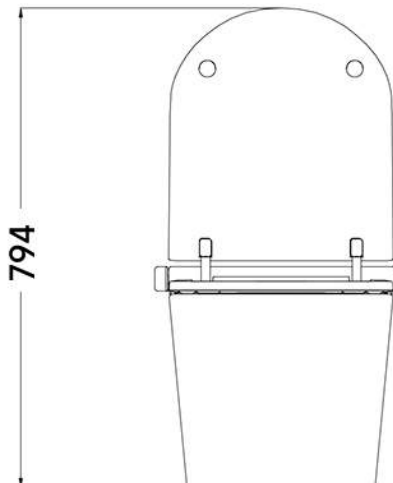
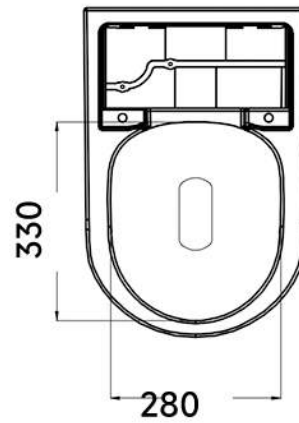

Dimensions

Milimeters - mm

Front View

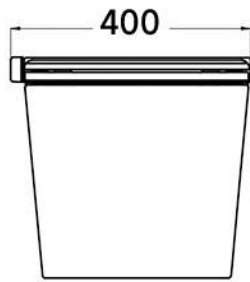

Side View

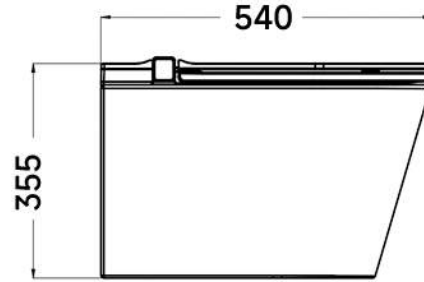

Seat Ring Inner Dia

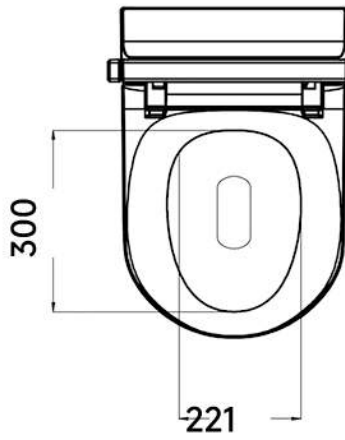

Ceramic Body Dia

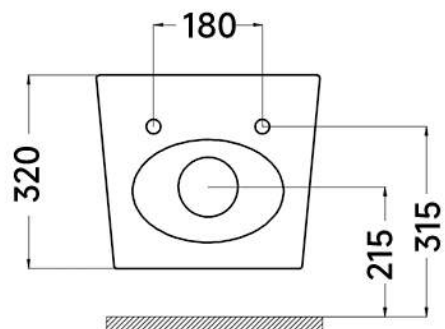
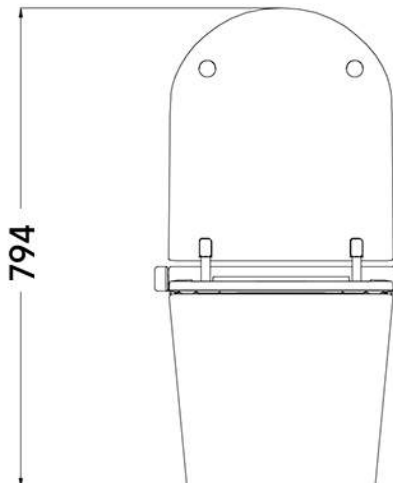
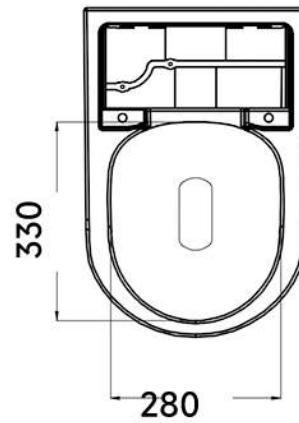

Bracket Dimensions

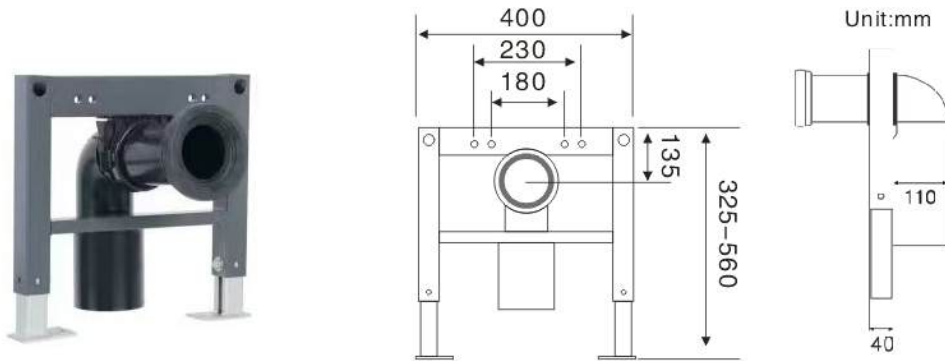

Note: Manual measurement may have slight deviations,
please refer to the actual product.

Product Name Wall mounted intelligent toilet	Heating method Instant heating	Power Cord 1.5m 3-hole socket
Product size 540x400x355mm	Theme Material ceramics	Drainage method Wall Outlet
Seat width 73mm	Flushing method Jet siphon	Rated voltage AC220V/50Hz
Installation pit distance 305/400/Other	Water pressure limitation No water pressure limitation	Water supply method Direct connection